



Powered by
ncnielsen
Lithium-ION 



Reach Truck

R 10 – R 25 HD | W | N

Capacity 1.0 – 2.5 t | Series 1120

Robust all-rounder with extensive safety options

- Efficient logistics handling in wide-ranging sectors thanks to model diversity and extensive equipment portfolio
- Safe handling of loads at height through visibility-optimized masts, automatic parking brake and Linde Curve Assist and load wheel brake as standard
- Sophisticated ergonomic concept ensures intuitive and fatigue-free operation
- Service intervals of 1000 operating hours with easy access and maintenance-free electric motors offer outstanding availability

STANDARD AND OPTIONAL EQUIPMENT

Model/Equipment		R10 N	R12 N	R14 N	R16 N	R16 N HD	R20 N	R14	R14 HD	R16	R16 HD	R20	R20 HD	R25	R20 W-1470	R20 W-1670
Safety	Linde Curve Assist	●	●	●	●	●	●	●	●	●	●	●	●	●	●	●
	Electrical and hydraulic overload protection	●	●	●	●	●	●	●	●	●	●	●	●	●	●	●
	Seat-actuated traction interlock	●	●	●	●	●	●	●	●	●	●	●	●	●	●	●
	Battery lock with creep speed interlock	●	●	●	●	●	●	●	●	●	●	●	●	●	●	●
	Protective polycarbonate screen between console and mast	●	●	●	●	●	●	●	●	●	●	●	●	●	●	●
	Lift height related travel speed reduction	●	●	●	●	●	●	●	●	●	●	●	●	●	●	●
	Automatic slowdown at end of reach travel and at max. lift	●	●	●	●	●	●	●	●	●	●	●	●	●	●	●
Service	Sealed, maintenance-free AC 6.5 kW drive and 14 kW lift motors	●	●	●	●	●	●	●	●	●	●	●	●	●	●	●
Digitalization	Comprehensive digital instrument display	●	●	●	●	●	●	●	●	●	●	●	●	●	●	●
	Connect Linde Fleet management	○	○	○	○	○	○	○	○	○	○	○	○	○	○	○
	Radio Data Terminal bracket	○	○	○	○	○	○	○	○	○	○	○	○	○	○	○
Operation/Load Handling	Linde Digital Control System (LDC)	●	●	●	●	●	●	●	●	●	●	●	●	●	●	●
	Linde rheological 180° electric steering with tactile feedback	●	●	●	●	●	●	●	●	●	●	●	●	●	●	●
	Single axis joysticks	○	○	○	○	○	○	○	○	○	○	○	○	○	○	○
	Multifunction Lever	○	○	○	○	○	○	○	○	○	○	○	○	○	○	○
	Lift height indicator above free lift zone	●	●	●	●	●	●	●	●	●	●	●	●	●	●	●
	Load weight indicator	○	○	○	○	○	○	○	○	○	○	○	○	○	○	○
	Lift height pre-selector	○	○	○	○	○	○	○	○	○	○	○	○	○	○	○
	Rack Protection Sensor	○	○	○	○	○	○	○	○	○	○	○	○	○	○	○
Environment	Height adjustable armrest	○	○	○	○	○	○	○	○	○	○	○	○	○	○	○
	Modular ambient cabin versions	–	–	–	–	–	–	○	○	○	○	○	○	○	○	○
	Cold store cabin	–	–	–	–	–	–	○	○	○	○	○	○	○	○	○
	Cold store protection to -30 °C	○	○	○	○	○	○	○	○	○	○	○	○	○	○	○
Electronics	Electric horn and Emergency isolator	●	●	●	●	●	●	●	●	●	●	●	●	●	●	●
	Linde Batteris and charger	○	○	○	○	○	○	○	○	○	○	○	○	○	○	○
	Linde Li-ION truck version and Li-ION batteries	○	○	○	○	○	○	○	○	○	○	○	○	○	○	○
	Vision system, combined cameras	○	○	○	○	○	○	○	○	○	○	○	○	○	○	○
Workplace	Fully adjustable air suspension seat	●	●	●	●	●	●	●	●	●	●	●	●	●	●	●
	Linde twin accelerator pedals	●	●	●	●	●	●	●	●	●	●	●	●	●	●	●
	Resiliently mounted operator's compartment	●	●	●	●	●	●	●	●	●	●	●	●	●	●	●
	Integral, adjustable control console	●	●	●	●	●	●	●	●	●	●	●	●	●	●	●
	Single accelerator pedal	○	○	○	○	○	○	○	○	○	○	○	○	○	○	○
	Heated seat	○	○	○	○	○	○	○	○	○	○	○	○	○	○	○
	High vision armoured glass roof	○	○	○	○	○	○	○	○	○	○	○	○	○	○	○
Mast	Wind protection door	–	–	–	–	–	–	○	○	○	○	○	○	○	○	○
	Tilting fork carriage and integral side shift	●	●	●	●	●	●	●	●	●	●	●	●	●	●	●
	Torsion-resistant fixed clear view triplex mast	○	○	○	○	○	○	○	○	○	○	○	○	○	○	○
	Mast mounted CCTV camera system	○	○	○	○	○	○	○	○	○	○	○	○	○	○	○
Attachment/Forks	Linde Dynamic Mast Control (DMC) with Electric Reach (ER)	–	–	–	–	–	–	○	○	○	○	○	○	–	–	–
	Side shift centering	○	○	○	○	○	○	○	○	○	○	○	○	○	○	○
	Horizontal fork leveling	○	○	○	○	○	○	○	○	○	○	○	○	○	○	○
	Green fork tips	–	–	○	○	○	○	○	○	○	○	○	○	○	○	○
Axles and Tyres	Additional hydraulic circuit for attachments	○	○	○	○	○	○	○	○	○	○	○	○	○	○	○
	Polyurethane drive and load wheels tires	●	●	●	●	●	●	●	●	●	●	●	●	●	●	●
	Load wheel protection	○	○	○	○	○	○	○	○	○	○	○	○	○	○	○
Drive and Brake-System	Side guidance wheels	○	○	○	○	○	○	○	○	○	○	○	○	○	○	○
	Four independent braking systems. Regenerative and counter current braking, holding brake control with automatic parking brake and all-wheel brake system	●	●	●	●	●	●	●	●	●	●	●	●	●	●	●
Lighting	2 VertiLights mounted on the mast	○	○	○	○	○	○	○	○	○	○	○	○	○	○	○
	LED working lights at over head guard	○	○	○	○	○	○	○	○	○	○	○	○	○	○	○
	Rotating/ flashing beacon	○	○	○	○	○	○	○	○	○	○	○	○	○	○	○
	Blue Spot™/ TruckSpot safety light	○	○	○	○	○	○	○	○	○	○	○	○	○	○	○
	Red Warning Lines	○	○	○	○	○	○	○	○	○	○	○	○	○	○	○

● Standard equipment ○ Optional equipment – Not available

TECHNICAL DATA (According to VDI 2198)

Characteristics	1.1	Manufacturer		LINDE	LINDE	LINDE	LINDE	LINDE	LINDE	LINDE	LINDE	LINDE	LINDE	LINDE	LINDE	LINDE	LINDE	LINDE
	1.2	Manufacturer's type designation		R10 N	R12 N	R14 N	R16 N	R16 N HD	R20 N	R14	R14 HD	R16	R16 HD	R20	R20 HD	R25	R20 W-1470	R20 W-1670
Weights	1.2a	Series		1120-00	1120-00	1120-00	1120-00	1120-00	1120-00	1120-00	1120-00	1120-00	1120-00	1120-00	1120-00	1120-00	1120-00	1120-00
	1.3	Power unit		Battery	Battery	Battery	Battery	Battery	Battery	Battery	Battery	Battery	Battery	Battery	Battery	Battery	Battery	Battery
Wheels / Tyres	1.4	Operation		Seat	Seat	Seat	Seat	Seat	Seat	Seat	Seat	Seat	Seat	Seat	Seat	Seat	Seat	Seat
	1.5	Load capacity / Load	Q (t)	1.0	1.2	1.4	1.6	1.6	2.0	1.4	1.4	1.6	1.6	2.0	2.0	2.5	2.0	2.0
Dimensions	1.6	Load centre distance	c (mm)	600/500	600/500	600/500	600/500	600/500	600/500	600/500	600/500	600/500	600/500	600/500	600/500	600/500	600/500	600/500
	1.8	Axle centre to fork face	x (mm)	223	223	401	396	169	259	399	276	466	348	348	420	415	345	345
Performance	1.9	Wheelbase	y (mm)	1275	1275	1453	1453	1453	1525	1381	1381	1453	1453	1525	1669	1669	1525	1525
	2.1	Service weight	kg	3050 ¹⁾	3050 ¹⁾	3080 ¹⁾	3080 ¹⁾	4090 ¹⁾	4235 ¹⁾	3065 ¹⁾	3990 ¹⁾	3075 ¹⁾	4115 ¹⁾	4470 ¹⁾	5360 ¹⁾	5360 ¹⁾	4620 ¹⁾	4700 ¹⁾
Others	2.3	Axle load without load front/rear	kg	1760/1290	1760/1290	1920/1160	1920/1160	2105/1985	2280/1955	1940/1125	2300/1690	1995/1080	2450/1665	2585/1885	3060/2300	3070/2290	2690/1930	2720/1980
	2.4	Axle load fork outreached with load front/rear	kg	600/3450	477/3773	706/3774	600/4080	804/4886	645/5590	665/3800	930/4460	745/3930	940/4775	830/5640	1200/6160	990/6870	920/5700	920/5780
Drive	2.5	Axle load fork retracted with load front/rear	kg	1464/2586	1405/2845	1728/2752	1695/2985	1630/4060	1833/4402	1736/2729	1970/3420	1847/2828	2170/3545	2255/4215	2845/4515	2790/5070	2360/4260	2390/4310
	3.1	Tyres rubber SE pneumatic polyurethane		Polyurethane	Polyurethane	Polyurethane	Polyurethane	Polyurethane	Polyurethane	Polyurethane	Polyurethane	Polyurethane	Polyurethane	Polyurethane	Polyurethane	Polyurethane	Polyurethane	Polyurethane
Performance	3.2	Tyre size front		Ø 360 × 130	Ø 360 × 130	Ø 360 × 130	Ø 360 × 130	Ø 360 × 130	Ø 360 × 140	Ø 360 × 130	Ø 360 × 130	Ø 360 × 130	Ø 360 × 130	Ø 360 × 140	Ø 360 × 140	Ø 360 × 140	Ø 360 × 140	Ø 360 × 140
	3.3	Tyre size rear		Ø 285 × 100	Ø 285 × 100	Ø 285 × 100	Ø 285 × 100	Ø 285 × 100	Ø 350 × 100	Ø 285 × 100	Ø 285 × 100	Ø 285 × 100	Ø 285 × 100	Ø 350 × 100	Ø 350 × 100	Ø 350 × 100	Ø 350 × 100	Ø 350 × 100
Performance	3.5	Wheels number front/rear (x = driven)		1x/2	1x/2	1x/2	1x/2	1x/2	1x/2	1x/2	1x/2	1x/2	1x/2	1x/2	1x/2	1x/2	1x/2	1x/2
	3.6	Track width front	b10 (mm)	0	0	0	0	0	0	0	0	0	0	0	0	0	0	0
Performance	3.7	Track width rear	b11 (mm)	1037	1037	1037	1037	1037	1037	1167	1167	1167	1167	1167	1167	1167	1367	1567
	4.1	Mast/fork carriage tilt forward/backward	a/b (°)	2.0/4.0	2.0/4.0	2.0/4.0	2.0/4.0	2.0/4.0	2.0/4.0	2.0/4.0	2.0/4.0	2.0/4.0	2.0/4.0	2.0/4.0	2.0/4.0	2.0/4.0	2.0/4.0	2.0/4.0
Performance	4.2	Height of mast lowered	h1 (mm)	2485	2485	2485	2485	3430	3655	2485	3265	2485	3366	3591	4516	4165	3591	3591
	4.3	Free lift	h2 (mm)	1636	1636	1636	1636	2301	2776	1636	2649	1636	2749	2974	3899	3549	2974	2974
Performance	4.4	Lift	h3 (mm)	5760	5760	5760	5760	8255	8955	5760	7955	5760	8255	8955	11455	10455	8955	8955
	4.5	Height of mast extended	h4 (mm)	6649	6649	6649	6649	9001	9701	6649	8511	6649	8811	9511	12011	11011	9511	9511
Performance	4.7	Height of overhead guard (cabin)	h6 (mm)	2110 ²⁾	2110 ²⁾	2110 ²⁾	2110 ²⁾	2110 ²⁾	2110 ²⁾	2110 ²⁾	2110 ²⁾	2110 ²⁾	2110 ²⁾	2110 ²⁾	2110 ²⁾	2110 ²⁾	2110 ²⁾	2110 ²⁾
	4.8	Seat height relating to SIP/stand height	h7 (mm)	910 - 1040	910 - 1040	910 - 1040	910 - 1040	910 - 1040	910 - 1040	910 - 1040	910 - 1040	910 - 1040	910 - 1040	910 - 1040	910 - 1040	910 - 1040	910 - 1040	910 - 1040
Performance	4.10	Height of reach legs	h8 (mm)	308	308	308	308	373	308	308	308	308	373	373	373	373	373	373
	4.19	Overall length	l1 (mm)	2423 ³⁾	2423 ³⁾	2423 ³⁾	2428 ³⁾	2655 ³⁾	2635 ³⁾	2351 ³⁾	2474 ³⁾	2356 ³⁾	2474 ³⁾	2546 ³⁾	2618 ³⁾	2673 ³⁾	2547 ³⁾	2546 ³⁾
Performance	4.20	Length to fork face	l2 (mm)	1273	1273	1273	1278	1505	1485	1201	1324	1206	1324	1396	1468	1473	1397	1396
	4.21	Overall width	b1/b2 (mm)	1140	1140	1140	1140	1140	1140	1270	1270	1270	1270	1270	1270	1270	1470	1670
Performance	4.22	Fork dimensions DIN ISO 2331	s/e/l (mm)	40 × 80 × 1150	40 × 80 × 1150	40 × 80 × 1150	45 × 100 × 1150	45 × 100 × 1150	45 × 100 × 1150	40 × 80 × 1150	45 × 100 × 1150	45 × 100 × 1150	45 × 100 × 1150	45 × 100 × 1150	45 × 100 × 1150	45 × 100 × 1150	50 × 120 × 1200	45 × 100 × 1150
	4.23	Fork carriage to ISO 2328 class/type A B		2A	2A	2A	2A	2A	2A	2A	2A	2A	2A	2A	2A	2A	2A	2A
Performance	4.24	Width of fork carriage	b3 (mm)	830	830	830	830	830	830	830	770	830	770	770	770	770	770	770
	4.25	Fork spread	b5 (mm)	316/600	316/600	316/600	316/600	316/520	316/600	296/690	316/710	296/690	316/710	316/710	316/710	316/710	316/710	316/710
Performance	4.26	Distance between wheel arms/loading surfaces	b4 (mm)	790	790	790	790	790	790	920	920	920	920	920	920	920	1120	1320
	4.28	Reach travel	l4 (mm)	409	409	587	587	359	479	585	448	657	520	553	625	625	550	550
Performance	4.31	Ground clearance below mast	m1 (mm)	75	75	75	75	75	75	75	75	75	75	75	75	75	75	75
	4.32	Ground clearance centre of wheelbase	m2 (mm)	70	70	70	70	70	70	70	70	70	70	70	65	65	70	70
Performance	4.34.1	Aisle width for pallets 1000 × 1200 crossways	Ast (mm)	2702 ^{3) 4)}	2702 ^{3) 4)}	2738 ^{3) 4)}	2741 ^{3) 4)}	2915 ^{3) 4)}	2913 ^{3) 4)}	2689 ^{3) 4)}	2782 ^{3) 4)}	2713 ^{3) 4)}	2796 ^{3) 4)}	2865 ^{3) 4)}	2951 ^{3) 4)}	2954 ^{3) 4)}	2899 ^{3) 4)}	2937 ^{3) 4)}
	4.34.2	Aisle width with pallet 800 × 1200 along forks	Ast (mm)	2776 ^{3) 4)}	2776 ^{3) 4)}	2784 ^{3) 4)}	2788 ^{3) 4)}	2996 ^{3) 4)}	2982 ^{3) 4)}	2735 ^{3) 4)}	2849 ^{3) 4)}	2746 ^{3) 4)}	2851 ^{3) 4)}	2920 ^{3) 4)}	2993 ^{3) 4)}	2997 ^{3) 4)}	2955 ^{3) 4)}	2993 ^{3) 4)}
Performance	4.35	Turning radius	Wa (mm)	1520 ³⁾	1520 ³⁾	1690 ³⁾	1690 ³⁾	1690 ³⁾	1760 ³⁾	1640 ³⁾	1641 ³⁾	1710 ³⁾	1778 ³⁾	1916 ³⁾	1916 ³⁾	1811 ³⁾	1849 ³⁾	
	4.37	Length of chassis	l7 (mm)	1641	1641	1819	1819	1819	1924	1737	1746	1817	1817	1922	2066	2066	1920	1919
Performance	5.1	Travel speed with/without load	km/h	14/14 ^{6) 7)}	14/14 ^{6) 7)}	14/14 ^{6) 7)}	14/14 ^{6) 7)}	14/14 ^{6) 7)}	14/14 ^{6) 7)}	14/14 ^{6) 7)}	14/14 ^{6) 7)}	14/14 ^{6) 7)}	14/14 ^{6) 7)}	14/14 ^{6) 7)}	14/14 ^{6) 7)}	14/14 ^{6) 7)}	14/14 ^{6) 7)}	14/14 ^{6) 7)}
	5.2	Lifting speed with/without load	m/s	0.57/0.7	0.55/0.7	0.53/0.7	0.51/0.7	0.45/0.7	0.43/0.52	0.53/0.7	0.55/0.76	0.51/0.7	0.52/0.76	0.46/0.76	0.40/0.59	0.40/0.59	0.45/0.76	0.45/0.76
Performance	5.3	Lowering speed with/without load	m/s	0.58/0.47	0.56/0.47	0.53/0.47	0.47/0.47	0.55/0.55	0.55/0.44	0.53/0.47	0.55/0.53	0.47/0.47	0.55/0.53	0.55/0.53	0.56/0.54	0.56/0.54	0.55/0.53	0.55/0.53
	5.4	Reach speed with/without load	m/s	0.2	0.2	0.2	0.2	0.2	0.2	0.2	0.2	0.2	0.2	0.2	0.2	0.2	0.2	0.2
Performance	5.8	Maximum climbing ability with/without load	%	10.0/10.0	10.0/10.0	10.0/10.0	10.0/10.0	10.0/10.0	10.0/10.0	10.0/10.0	10.0/10.0	10.0/10.0	10.0/10.0	10.0/10.0	10.0/10.0	10.0/10.0	10.0/10.0	10.0/10.0
	5.9	Acceleration time with/without load	s	4.7/4.6	4.7/4.6	4.7/4.6	4.8/4.6	3.8/3.6	5.1/4.7	4.7/4.6	4.8/4.7	4.8/4.7	4.9/4.7	5.1/4.7	5.3/4.8	5.4/4.8	5.2/4.7	5.2/4.7
Performance	5.10	Service brake		hydr./mech.	hydr./mech.	hydr./mech.	hydr./mech.	hydr./mech.	hydr./mech.	hydr./mech.	hydr./mech.	hydr./mech.	hydr./mech.	hydr./mech.	hydr./mech.	hydr./mech.	hydr./mech.	hydr./mech.
	6.1	Drive motor rating S2 60 min	kW	6.5	6.5	6.5	6.5	6.5	6.5	6.5	6.5	6.5	6.5	6.5	6.5	6.5	6.5	6.5
Performance	6.2	Lift motor rating at S3 15 %	kW	14	14	14	14	14	14	14	14	14	14	14	14	14	14	14
	6.3	Battery according to DIN 43531/35/36 A B C no		43 531 B	43 531 B	43 531 B	43 531 B	43 531 B	43 531 B	43 531 B	43 531 C/[Li-ION]	43 531 C/[Li-ION]	43 531 C/[Li-ION]	43 531 C/[Li-ION]	43 531 C/[Li-ION]	43 531 C/[Li-ION]	43 531 C/[Li-ION]	43 531 C/[Li-ION]
Performance	6.4	Battery voltage/ rated capacity (5 h)	(V)/(Ah) o. kWh	48/420/465 ¹⁾	48/420/465 ¹⁾	48/420/465 ¹⁾	48/420/465 ¹⁾	48/700/775 ¹⁾	48/700/775 ¹⁾	48/420/465 [48/201] ^{1) 8)}	48/560/620 [48/804] ^{1) 8)}	48/420/465 [48/201] ^{1) 8)}	48/560/620 [48/804] ^{1) 8)}	48/700/775 [48/804] ^{1) 8)}	48/840/930 [48/804] ^{1) 8)}	48/700/775 [48/804] ^{1) 8)}	48/840/930 [48/804] ^{1) 8)}	48/700/775 [48/804] ^{1) 8)}
	6.4.a	Battery energy content	kWh	-	-	-	-	-	-	[9.8] ⁸⁾	[39.2] ⁸⁾	[9.8] ⁸⁾	[39.2] ⁸⁾	[39.2] ⁸⁾	[39.2] ⁸⁾	[39.2] ⁸⁾	[39.2] ⁸⁾	[39.2] ⁸⁾
Performance	6.5	Battery weight (± 5 %)	kg	746	746	746	746	1119	1119	750	939	750	939	1119	1306 [1119] ⁸⁾	1306 [1119] ⁸⁾	1119	

MAST TABLES

TRIPLEX MAST (in mm)

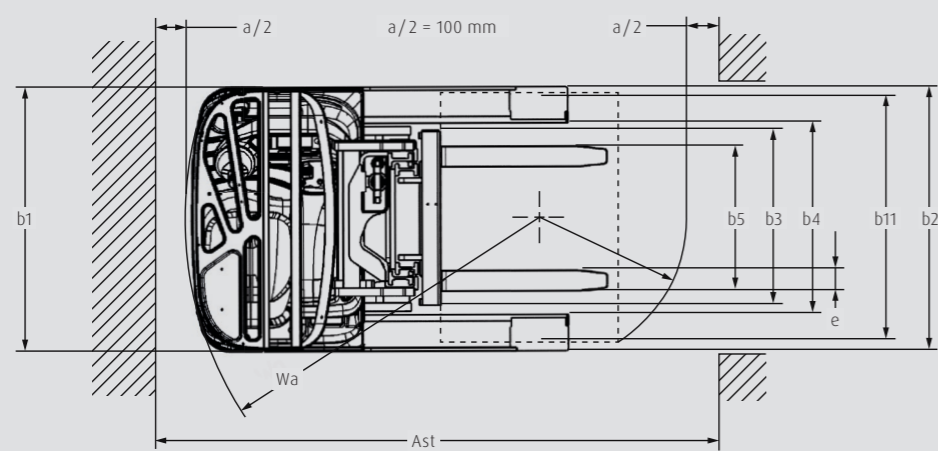
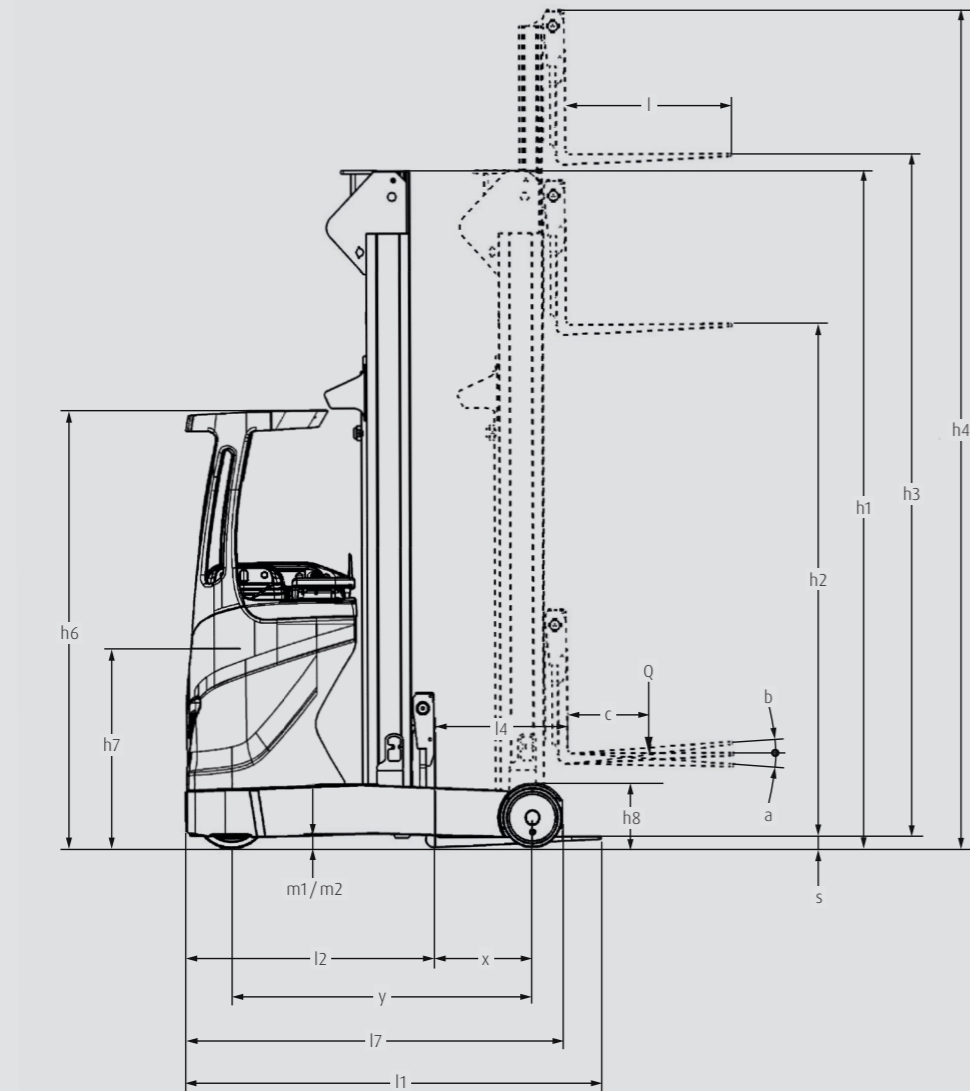

Series	1501										
Lift	h3: 4660	h3: 5160	h3: 5760	h3: 6260	h3: 6660	h3: 6960	h3: 7260	h3: 7560	h3: 7960	h3: 8260	h3: 8560
Height measurements	h1: 2135 h2: 1286 h3: 4660 h4: 5549	h1: 2285 h2: 1436 h3: 5160 h4: 6049	h1: 2485 h2: 1636 h3: 5760 h4: 6649	h1: 2660 h2: 1811 h3: 6260 h4: 7149	h1: 2785 h2: 1936 h3: 6660 h4: 7549	h1: 2910 h2: 2061 h3: 6960 h4: 7549	h1: 3010 h2: 2161 h3: 7260 h4: 8149	h1: 3110 h2: 2261 h3: 7560 h4: 8449	h1: 3260 h2: 2411 h3: 7960 h4: 8849	h1: 3360 h2: 2511 h3: 8260 h4: 9149	h1: 3485 h2: 2636 h3: 8560 h4: 9449
Model	<input type="checkbox"/>	<input type="checkbox"/>	<input type="checkbox"/>	<input type="checkbox"/>	<input type="checkbox"/>	<input type="checkbox"/>	<input type="checkbox"/>	<input type="checkbox"/>	<input type="checkbox"/>	<input type="checkbox"/>	<input type="checkbox"/>
R10 N - R12 N	<input type="checkbox"/>	<input type="checkbox"/>	<input type="checkbox"/>	<input type="checkbox"/>	<input type="checkbox"/>	<input type="checkbox"/>	<input type="checkbox"/>	<input type="checkbox"/>	<input type="checkbox"/>	<input type="checkbox"/>	<input type="checkbox"/>
R14 N - R16 N	<input type="checkbox"/>	<input type="checkbox"/>	<input type="checkbox"/>	<input type="checkbox"/>	<input type="checkbox"/>	<input type="checkbox"/>	<input type="checkbox"/>	<input type="checkbox"/>	<input type="checkbox"/>	<input type="checkbox"/>	<input type="checkbox"/>
R14 - R16	<input type="checkbox"/>	<input type="checkbox"/>	<input type="checkbox"/>	<input type="checkbox"/>	<input type="checkbox"/>	<input type="checkbox"/>	<input type="checkbox"/>	<input type="checkbox"/>	<input type="checkbox"/>	<input type="checkbox"/>	<input type="checkbox"/>

Series	1502										
Lift	h3: 4355	h3: 5155	h3: 6355	h3: 6955	h3: 7555	h3: 8255	h3: 8955	h3: 9155	h3: 9555	h3: 9855	h3: 10055
Height measurements	h1: 2130 h2: 1001 h3: 4355 h4: 5101	h1: 2380 h2: 1251 h3: 5155 h4: 5901	h1: 2780 h2: 1651 h3: 6355 h4: 7101	h1: 2980 h2: 1851 h3: 6955 h4: 7701	h1: 3180 h2: 2051 h3: 7555 h4: 8301	h1: 3430 h2: 2301 h3: 8255 h4: 9001	h1: 3655 h2: 2526 h3: 8955 h4: 9701	h1: 3730 h2: 2601 h3: 9155 h4: 9901	h1: 3855 h2: 2726 h3: 9555 h4: 10301	h1: 3980 h2: 2851 h3: 9855 h4: 10601	h1: 4080 h2: 2951 h3: 10055 h4: 10801
Model	<input type="checkbox"/>	<input type="checkbox"/>	<input type="checkbox"/>	<input type="checkbox"/>	<input type="checkbox"/>	<input type="checkbox"/>	<input type="checkbox"/>	<input type="checkbox"/>	<input type="checkbox"/>	<input type="checkbox"/>	<input type="checkbox"/>
R16 N HD	<input type="checkbox"/>	<input type="checkbox"/>	<input type="checkbox"/>	<input type="checkbox"/>	<input type="checkbox"/>	<input type="checkbox"/>	<input type="checkbox"/>	<input type="checkbox"/>	<input type="checkbox"/>	<input type="checkbox"/>	<input type="checkbox"/>
R20 N	<input type="checkbox"/>	<input type="checkbox"/>	<input type="checkbox"/>	<input type="checkbox"/>	<input type="checkbox"/>	<input type="checkbox"/>	<input type="checkbox"/>	<input type="checkbox"/>	<input type="checkbox"/>	<input type="checkbox"/>	<input type="checkbox"/>

Series	1506										
Lift	h3: 4355	h3: 4755	h3: 5255	h3: 5755	h3: 6255	h3: 6755	h3: 7255	h3: 7755	h3: 8255	h3: 8755	h3: 9255
Height measurements	h1: 2065 h2: 1449 h3: 4355 h4: 4910	h1: 2190 h2: 1574 h3: 4755 h4: 5310	h1: 2365 h2: 1749 h3: 5255 h4: 5810	h1: 2540 h2: 1924 h3: 5755 h4: 6310	h1: 2690 h2: 2074 h3: 6255 h4: 6810	h1: 2865 h2: 2249 h3: 6755 h4: 7310	h1: 3040 h2: 2424 h3: 7255 h4: 7810	h1: 3190 h2: 2574 h3: 7755 h4: 8310	h1: 3365 h2: 2749 h3: 8255 h4: 8810	h1: 3540 h2: 2924 h3: 8755 h4: 9310	h1: 3690 h2: 3074 h3: 9255 h4: 9810
Model	<input type="checkbox"/>	<input type="checkbox"/>	<input type="checkbox"/>	<input type="checkbox"/>	<input type="checkbox"/>	<input type="checkbox"/>	<input type="checkbox"/>	<input type="checkbox"/>	<input type="checkbox"/>	<input type="checkbox"/>	<input type="checkbox"/>
R14 HD - R20 HD	<input type="checkbox"/>	<input type="checkbox"/>	<input type="checkbox"/>	<input type="checkbox"/>	<input type="checkbox"/>	<input type="checkbox"/>	<input type="checkbox"/>	<input type="checkbox"/>	<input type="checkbox"/>	<input type="checkbox"/>	<input type="checkbox"/>
R20	<input type="checkbox"/>	<input type="checkbox"/>	<input type="checkbox"/>	<input type="checkbox"/>	<input type="checkbox"/>	<input type="checkbox"/>	<input type="checkbox"/>	<input type="checkbox"/>	<input type="checkbox"/>	<input type="checkbox"/>	<input type="checkbox"/>
R25	<input type="checkbox"/>	<input type="checkbox"/>	<input type="checkbox"/>	<input type="checkbox"/>	<input type="checkbox"/>	<input type="checkbox"/>	<input type="checkbox"/>	<input type="checkbox"/>	<input type="checkbox"/>	<input type="checkbox"/>	<input type="checkbox"/>
R20 W-1470 I 1670	<input type="checkbox"/>	<input type="checkbox"/>	<input type="checkbox"/>	<input type="checkbox"/>	<input type="checkbox"/>	<input type="checkbox"/>	<input type="checkbox"/>	<input type="checkbox"/>	<input type="checkbox"/>	<input type="checkbox"/>	<input type="checkbox"/>

Series	1506										
Lift	h3: 9755	h3: 10255	h3: 10755	h3: 11255	h3: 11755	h3: 12255	h3: 12755	h3: 13255	h3: 13755	h3: 14255	h3: 14955
Height measurements	h1: 3865 h2: 3249 h3: 9755 h4: 10310	h1: 4090 h2: 3474 h3: 10255 h4: 10810	h1: 4265 h2: 3649 h3: 10755 h4: 11410	h1: 4440 h2: 3824 h3: 11255 h4: 11810	h1: 4615 h2: 3999 h3: 11755 h4: 12310	h1: 4765 h2: 4149 h3: 12255 h4: 12810	h1: 4940 h2: 4324 h3: 12755 h4: 13310	h1: 5115 h2: 4499 h3: 13255 h4: 13810	h1: 5265 h2: 4649 h3: 13755 h4: 14310	h1: 5440 h2: 4824 h3: 14255 h4: 14810	h1: 5665 h2: 5049 h3: 14955 h4: 15510
Model	<input type="checkbox"/>	<input type="checkbox"/>	<input type="checkbox"/>	<input type="checkbox"/>	<input type="checkbox"/>	<input type="checkbox"/>	<input type="checkbox"/>	<input type="checkbox"/>	<input type="checkbox"/>	<input type="checkbox"/>	<input type="checkbox"/>
R14 HD - R16 HD	<input type="checkbox"/>	<input type="checkbox"/>	<input type="checkbox"/>	<input type="checkbox"/>	<input type="checkbox"/>	<input type="checkbox"/>	<input type="checkbox"/>	<input type="checkbox"/>	<input type="checkbox"/>	<input type="checkbox"/>	<input type="checkbox"/>
R20	<input type="checkbox"/>	<input type="checkbox"/>	<input type="checkbox"/>	<input type="checkbox"/>	<input type="checkbox"/>	<input type="checkbox"/>	<input type="checkbox"/>	<input type="checkbox"/>	<input type="checkbox"/>	<input type="checkbox"/>	<input type="checkbox"/>
R20 HD	<input type="checkbox"/>	<input type="checkbox"/>	<input type="checkbox"/>	<input type="checkbox"/>	<input type="checkbox"/>	<input type="checkbox"/>	<input type="checkbox"/>	<input type="checkbox"/>	<input type="checkbox"/>	<input type="checkbox"/>	<input type="checkbox"/>
R20 W-1470 I 1670	<input type="checkbox"/>	<input type="checkbox"/>	<input type="checkbox"/>	<input type="checkbox"/>	<input type="checkbox"/>	<input type="checkbox"/>	<input type="checkbox"/>	<input type="checkbox"/>	<input type="checkbox"/>	<input type="checkbox"/>	<input type="checkbox"/>

Optional equipment Not available
h1: Height of mast, lowered **h2:** Free lift **h3:** Lift **h4:** Height of mast, extended

CHARACTERISTICS



Ergonomics as standard

Ergonomics

- Maximum operating comfort due to Multifunction Lever and padded armrests with the preciseness of Linde Load Control
- Sophisticated ergonomic concept ensures intuitive and fatigue-free work
- All components and control elements individually adjustable
- Air-suspended seat that adapts to operator's weight and vibration-free operator compartment for greater comfort on uneven surfaces as standard
- Effective and convenient operation via intuitive controls and low access height



Multifunction Lever

Handling

- Linde Load Control and Multifunction Lever offers a precise load handling
- Powerful drive and lift motors enable high load throughput
- Smooth, precise control of traction and hydraulic functions with Linde Digital Control System
- Excellent maneuverability in confined conditions and at height thanks to short wheelbase and dual-pedal system

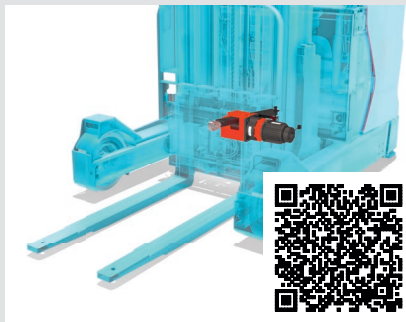

Unique ER and DMC system

Safety

- Linde Dynamic Mast Control with Electrical Reach, automatically compensates the dynamic mast oscillations and static deflections
- Safer load handling at height due to torsion-resistant triplex masts
- Monitoring system stops truck in the event of traction, steering or lift failure, plus auto-braking if driver exits cabin
- Safe cornering with Linde Curve Assist
- Clear view thanks to mast designed for optimal visibility
- Battery lock with creep speed interlock



Unique Rack Protection System RPS

Productivity

- Linde Rack Protection System reduces rack damages and rack service costs
- Utilization of full rack capacity
- Supports temporary operators
- Increases Productivity

Subject to modification in the interest of progress. Illustrations and technical details could include options and not binding for actual constructions. All dimensions subject to usual tolerances.